

- Copyright for test papers and marking guides remains with *West Australian Test Papers*.
- The papers may only be reproduced within the purchasing school according to the advertised conditions of sale.
- Test papers must be withdrawn after use and stored securely in the school until Wednesday 12th October 2016.



CHEMISTRY

UNITS 3 & 4

Semester 2, 2016

MARKING GUIDE

Section One: Multiple-choice

25% (50 marks)

1	a <input type="checkbox"/>	b <input checked="" type="checkbox"/>	c <input type="checkbox"/>	d <input type="checkbox"/>
2	a <input type="checkbox"/>	b <input type="checkbox"/>	c <input checked="" type="checkbox"/>	d <input type="checkbox"/>
3	a <input type="checkbox"/>	b <input type="checkbox"/>	c <input type="checkbox"/>	d <input checked="" type="checkbox"/>
4	a <input type="checkbox"/>	b <input type="checkbox"/>	c <input type="checkbox"/>	d <input checked="" type="checkbox"/>
5	a <input type="checkbox"/>	b <input type="checkbox"/>	c <input checked="" type="checkbox"/>	d <input type="checkbox"/>

11	a <input checked="" type="checkbox"/>	b <input type="checkbox"/>	c <input type="checkbox"/>	d <input type="checkbox"/>
12	a <input type="checkbox"/>	b <input type="checkbox"/>	c <input checked="" type="checkbox"/>	d <input type="checkbox"/>
13	a <input type="checkbox"/>	b <input type="checkbox"/>	c <input type="checkbox"/>	d <input checked="" type="checkbox"/>
14	a <input type="checkbox"/>	b <input checked="" type="checkbox"/>	c <input type="checkbox"/>	d <input type="checkbox"/>
15	a <input checked="" type="checkbox"/>	b <input type="checkbox"/>	c <input type="checkbox"/>	d <input type="checkbox"/>

21	a <input type="checkbox"/>	b <input type="checkbox"/>	c <input checked="" type="checkbox"/>	d <input type="checkbox"/>
22	a <input type="checkbox"/>	b <input type="checkbox"/>	c <input type="checkbox"/>	d <input checked="" type="checkbox"/>
23	a <input type="checkbox"/>	b <input checked="" type="checkbox"/>	c <input type="checkbox"/>	d <input type="checkbox"/>
24	a <input type="checkbox"/>	b <input type="checkbox"/>	c <input type="checkbox"/>	d <input checked="" type="checkbox"/>
25	a <input type="checkbox"/>	b <input checked="" type="checkbox"/>	c <input type="checkbox"/>	d <input type="checkbox"/>

6	a <input type="checkbox"/>	b <input checked="" type="checkbox"/>	c <input type="checkbox"/>	d <input type="checkbox"/>
7	a <input checked="" type="checkbox"/>	b <input type="checkbox"/>	c <input type="checkbox"/>	d <input type="checkbox"/>
8	a <input type="checkbox"/>	b <input type="checkbox"/>	c <input type="checkbox"/>	d <input checked="" type="checkbox"/>
9	a <input checked="" type="checkbox"/>	b <input type="checkbox"/>	c <input type="checkbox"/>	d <input type="checkbox"/>
10	a <input type="checkbox"/>	b <input type="checkbox"/>	c <input checked="" type="checkbox"/>	d <input type="checkbox"/>

16	a <input type="checkbox"/>	b <input type="checkbox"/>	c <input checked="" type="checkbox"/>	d <input type="checkbox"/>
17	a <input checked="" type="checkbox"/>	b <input type="checkbox"/>	c <input type="checkbox"/>	d <input type="checkbox"/>
18	a <input type="checkbox"/>	b <input type="checkbox"/>	c <input type="checkbox"/>	d <input checked="" type="checkbox"/>
19	a <input checked="" type="checkbox"/>	b <input type="checkbox"/>	c <input type="checkbox"/>	d <input type="checkbox"/>
20	a <input type="checkbox"/>	b <input type="checkbox"/>	c <input type="checkbox"/>	d <input checked="" type="checkbox"/>

(2 marks per question)

Section Two: Short answer**35% (70 marks)**

This section has **10** questions. Answer **all** questions. Write your answers in the spaces provided.

When calculating numerical answers, show your working or reasoning clearly. Express numerical answers to the appropriate number of significant figures and include appropriate units where applicable.

Spare pages are included at the end of this booklet. They can be used for planning your responses and/or as additional space if required to continue an answer.

- Planning: If you use the spare pages for planning, indicate this clearly at the top of the page.
- Continuing an answer: If you need to use the space to continue an answer, indicate in the original answer space where the answer is continued, i.e. give the page number. Fill in the number of the question(s) that you are continuing to answer at the top of the page.

Suggested working time: 60 minutes.

Question 26**(8 marks)**

Tuftsins is a tetrapeptide (a molecule consisting of four amino acid residues) which is produced by the spleen. It has been found that people with low levels of tuftsins in their bodies are susceptible to repeated frequent infections of the skin, lymph nodes and lungs. Low tuftsins levels can be inherited genetically or can be the result of a spleen operation. The tuftsins tetrapeptide molecule is shown below.

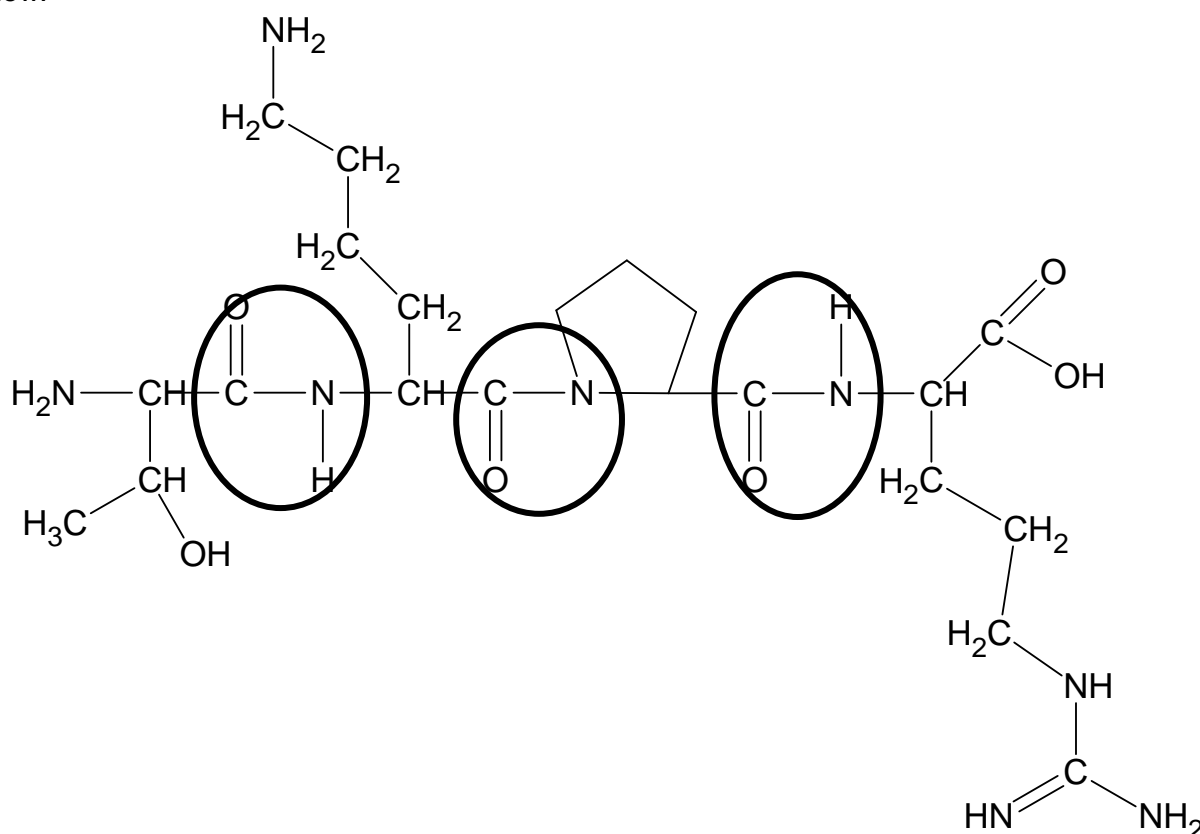

- (a) On the diagram above, circle the peptide bonds and then complete the primary sequence of tuftsins below using the standard three letter abbreviations. (3 marks)

thr – lys – pro – arg (1m circles, 2m aa's)

One medical study has shown that some people have a genetic mutation which causes the lysine residue in tuftsin to be replaced with a glutamic acid residue instead.

- (b) Draw a diagram of glutamic acid in zwitterion form and use this example to explain what a zwitterion is. (2 marks)

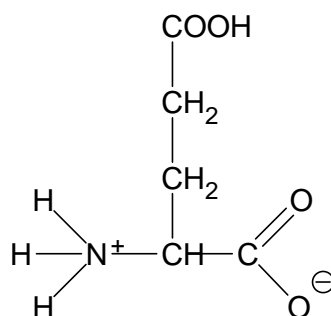

- (1m diagram)
- zwitterion is a species with both a positive and negative charge, however overall charge of species remains zero

(you may accept either site for COO⁻ group)

In the mutated form of tuftsin, the primary sequence of the tetrapeptide has been changed, altering its function.

- (c) In general terms, explain how alteration of the primary sequence of a protein can affect its secondary and tertiary structures. (3 marks)
- secondary structures such as α -helices and β -sheets form due to H-bonding between amino acid side chains
 - the various tertiary structures (eg disulfide bridges) also form due to amino acid side chain interactions
 - alteration of primary structure means different amino acids with different side chains are incorporated, therefore the same secondary and tertiary structures will not be able to form

Question 27**(8 marks)**

Consider the equation for the following reversible chemical system. Gaseous hydrogen and bromine were injected into an empty flask and allowed to establish equilibrium at 25 °C.

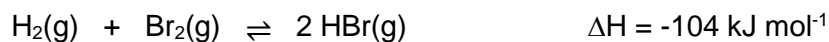

The activation energy for this reaction is 188 kJ mol⁻¹. The value of K_c for this reaction at 25 °C is 2.0 x 10¹⁹.

(a) Does this question refer to an open or closed system? Explain. (2 marks)

- **closed**
- **question states that equilibrium was established**

(b) What information does the value of K_c provide about the; (2 marks)

- (i) equilibrium position?
- **strongly favours product at 25 °C**
- (ii) rate of reaction?
- **nothing**

(c) Draw an energy profile diagram for this reaction. Label the activation energy and the enthalpy change. (4 marks)

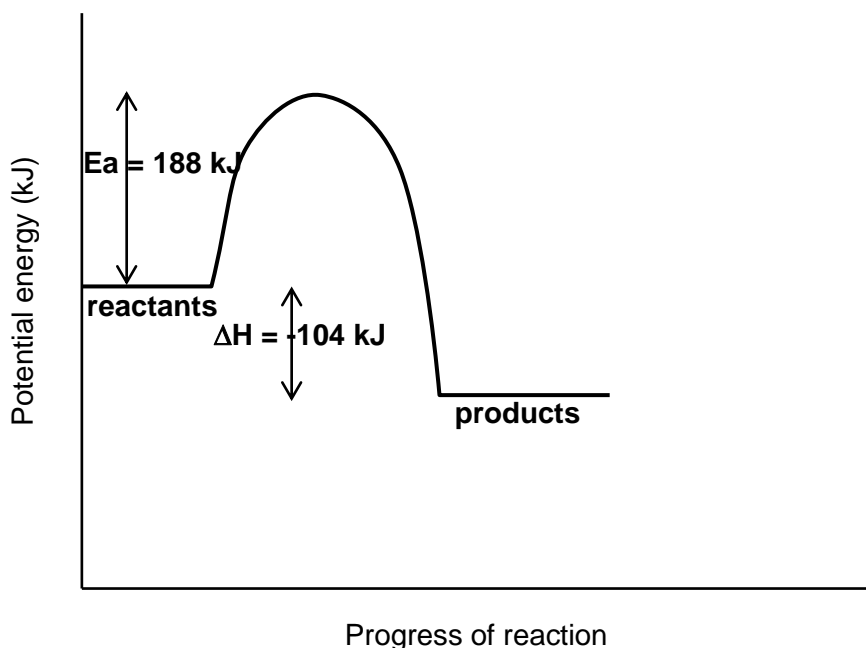

(1m ΔH, 1m Ea, 1m exothermic, 1m proportion of Ea/ΔH approximate)

Question 28**(7 marks)**

Bromocresol green is an indicator that can be used in biological laboratories when growing microorganisms as well as for titrations or as a tracking dye. It displays two colours, yellow and blue, as shown in the diagram below.

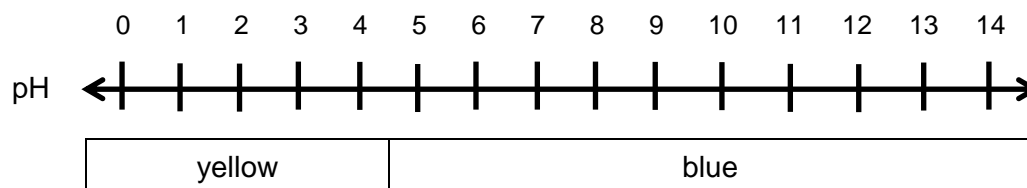

(a) What types of substances are acid-base indicators? (2 marks)

- **weak acids or weak bases**
- **where the acidic form is different colour to basic form**

(b) What colour would the following aqueous solutions turn, if a few drops of bromocresol green was added to each? Use a chemical equation to support your answer where appropriate. (3 marks)

Solution	Colour	Chemical equation
Mg(NO ₃) ₂ (aq)	blue	NR (zero marks allocated)
Na ₂ SO ₃ (aq)	blue	SO₃²⁻ + H₂O ⇌ HSO₃⁻ + OH⁻

A standardised solution of hydrochloric acid, HCl(aq), was being used in a titration with a sodium hydrogencarbonate solution, NaHCO₃(aq), of unknown concentration.

(c) Would bromocresol green be an appropriate indicator for this titration? Explain your answer. (2 marks)

- **yes**
- **equivalence point would be acidic due to CO₂(aq) production, so indicator with acidic end point is required**

Question 29**(6 marks)**

Tin is a metallic element located in Group 14 of the periodic table. It is used to make many different alloys such as bronze and solder, as well as finding application in the plating of steel to produce 'tin cans' for storage.

A chemistry student had 1.0 mol L⁻¹ solutions of the following four substances;

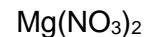
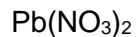
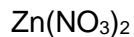

(a) Which of these solutions could **not** be stored in a tin container? Explain your answer using a relevant chemical equation. (3 marks)

- **Pb(NO₃)₂**
- **metal displacement reaction would occur OR Pb²⁺ has higher E⁰ value than Sn²⁺ and will cause oxidation of tin container**
- **Pb²⁺(aq) + Sn(s) → Pb(s) + Sn²⁺(aq)**

When tin metal is placed in an acidified solution containing the weak acid hydrogen chromate (HCrO₄⁻) a deep green solution containing chromium(III) ions is formed, and the tin metal dissolves producing tin(II) ions.

(b) Write the oxidation and reduction half-equations and the overall redox equation for this reaction. (3 marks)

Oxidation half-equation	Sn → Sn²⁺ + 2 e⁻
Reduction half-equation	HCrO₄⁻ + 7 H⁺ + 3 e⁻ → Cr³⁺ + 4 H₂O
Overall redox equation	2 HCrO₄⁻ + 14 H⁺ + 3 Sn → 2 Cr³⁺ + 3 Sn²⁺ + 8 H₂O

Question 30**(7 marks)**

Consider the various organic molecules shown below.

- (a) Circle and name the three (3) remaining functional groups on the molecule below. (One functional group has been circled for you.) (3 marks)

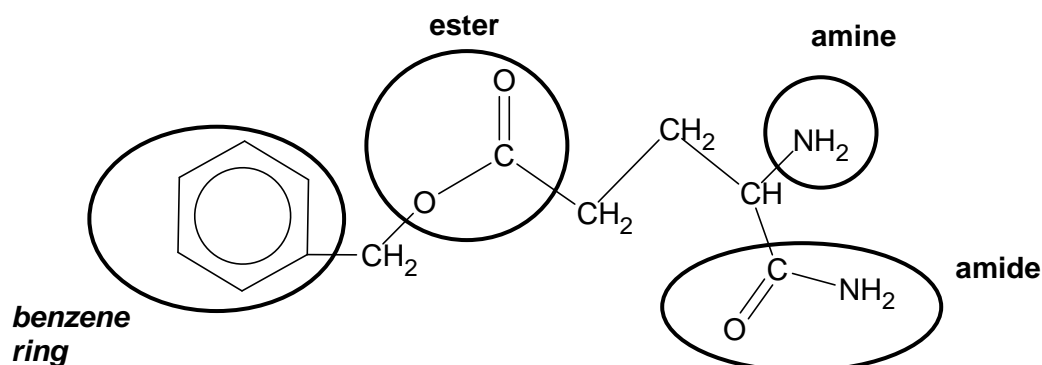

- (b) Give the IUPAC names for the following organic molecules. (2 marks)

$ \begin{array}{ccccccc} & \text{H} & \text{H} & \text{H} & \text{CH}_3 & & \\ & & & & & & \text{O} \\ \text{H} & - \text{C} & - \text{C} & - \text{C} & - \text{C} & - & \text{C} \\ & & & & & & // \\ & \text{H} & \text{H} & \text{CH}_3 & \text{H} & & \text{O} \\ & & & & & & \backslash \\ & & & & & & \text{OH} \end{array} $	$ \begin{array}{cccc} & \text{Br} & \text{H} & \text{H} \\ & & & \\ \text{H} & - \text{C} & - \text{C} & - \text{C} - \text{OH} \\ & & & \\ & \text{H} & \text{Cl} & \text{H} \end{array} $
Name: 2,3-dimethylpentanoic acid	Name: 3-bromo-2-chloropropan-1-ol

- (c) If the two substances shown in part (b) were mixed together and warmed in the presence of sulfuric acid; (2 marks)

(i) name the type of reaction that would occur.

- **esterification**

(ii) draw the structure of the organic product that would form.

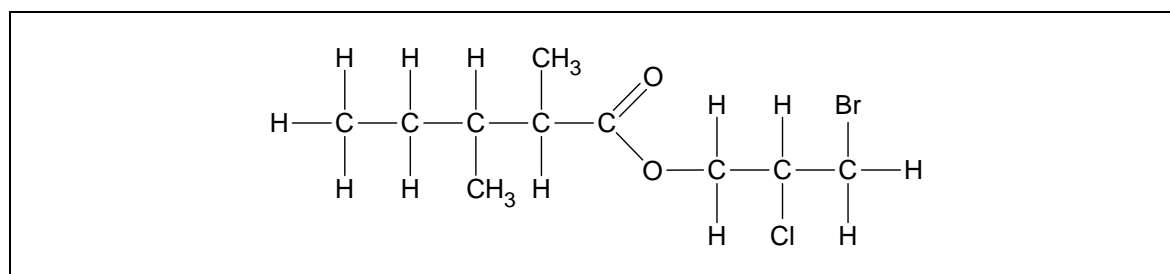

Question 31**(7 marks)**

Ammonium carbamate can decompose in a reversible, endothermic reaction, according to the chemical equation shown below.

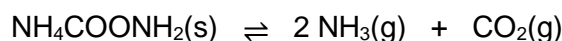

- (a) If the total volume of the system was decreased, state the effect this would have on the equilibrium position and note an observation. (2 marks)

equilibrium position: **favour reverse / shift to left**

observation: **more solid forms**

- (b) If the temperature of the system was decreased, explain the effect this would have on the equilibrium in terms of reaction rates. (3 marks)

- **both forward and reverse reaction rates would decrease, due to a decreased average kinetic energy of particles**
- **the endothermic direction (forwards) is always affected to a greater extent by temperature change, and is therefore decreased more than the reverse rate**
- **results in reverse reaction being favoured until the system re-establishes equilibrium, where the forward and reverse rates are again equal (but lower than initially)**

- (c) One of the products of this decomposition reaction is carbon dioxide gas. Write two (2) chemical equations that illustrate how increasing atmospheric CO₂ levels may contribute to ocean acidification. (2 marks)

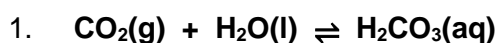

Question 32**(6 marks)**

Hydrofluoric acid, HF(aq), is a colourless, highly corrosive solution, used in the manufacture of many pharmaceuticals. Hydrofluoric acid has a K_a value of 6.76×10^{-4} .

- (a) Write an equilibrium constant (K_a) expression for the ionisation of HF in water and explain what information the value of K_a provides. (2 marks)

- $K_a = \frac{[\text{H}_3\text{O}^+][\text{F}^-]}{[\text{HF}]}$
- **value significantly lower than 1, therefore ionisation happens to a small extent and HF is a weak acid**

A student was given 0.500 L of a 0.250 mol L^{-1} hydrofluoric acid solution and instructed to produce a buffer.

- (b) What substance could the student add to the HF(aq) to produce a buffer? Explain your answer. (2 marks)

- **any solution of a fluoride salt (eg NaF, KF...)**
(preferably an equimolar amount, ie 0.125 mol)
- **this would provide the conjugate base F^- which would form a buffer with HF**

OR

- **a small amount of any solution of a strong base (eg NaOH, KOH...)**
(preferably half the number of moles of HF, ie 0.0625 mol)
- **this would partially neutralise HF, producing F^- , which would then form the buffer**

- (c) Write a chemical equation for the buffer system that would be formed and label the conjugate acid-base pairs. (2 marks)

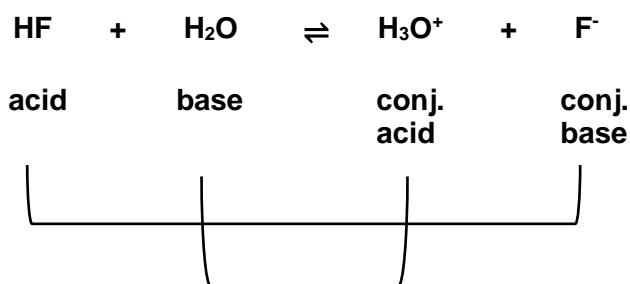

Question 33

(5 marks)

Consider the electrochemical cell shown below.

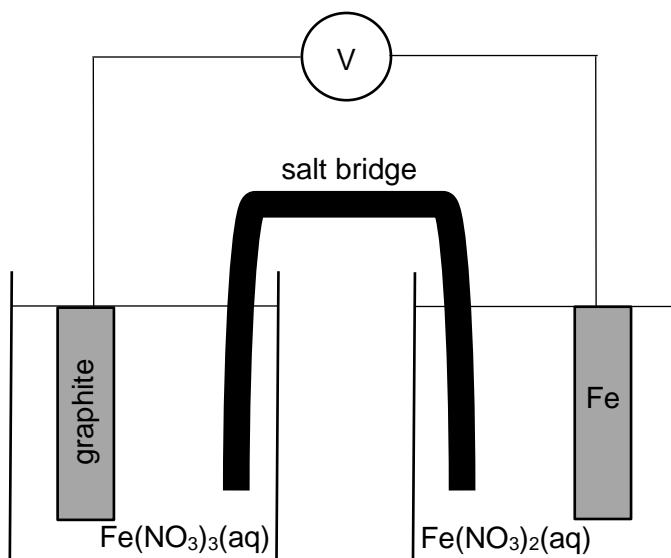

- (a) Determine the half-equations occurring at each electrode. (2 marks)

Cathode	$\text{Fe}^{3+} + \text{e}^- \rightarrow \text{Fe}^{2+}$
Anode	$\text{Fe} \rightarrow \text{Fe}^{2+} + 2 \text{e}^-$

- (b) Calculate the EMF of this cell under standard conditions. (1 mark)

- **+1.21 V**

- (c) Note an observation for each electrode. (2 marks)

Cathode	pale brown solution slowly changes colour to pale green
Anode	electrode disintegrates / becomes smaller OR solution becomes greener in colour

Question 35**(7 marks)**

The structure of a detergent molecule called 'branched dodecylbenzene sulfonate' is shown below.

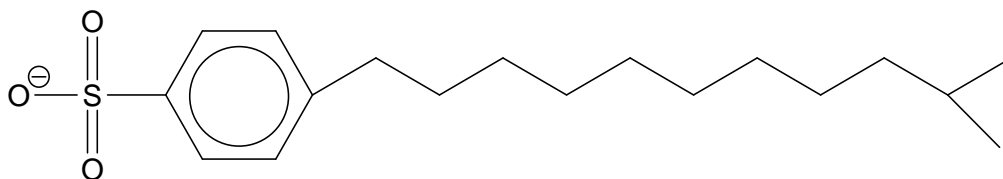

- (a) Note one similarity and one difference between the structure of this detergent molecule and a soap molecule. (2 marks)

Similarity	soaps and detergents both have - a non-polar hydrophobic hydrocarbon tail - polar hydrophilic head
Difference	main difference - detergents have charged polar sulfonate group (SO_3^-) - soaps have a charged polar carboxylate group (COO^-)

- (b) Describe the cleaning action of detergents. Include in your answer a discussion of the advantage detergents have over soaps when used in hard water. (5 marks)

- polar hydrophilic head of molecule remains dissolved in polar water
- non-polar hydrophobic tail dissolves in non-polar fats/oil/grease/dirt
- these interactions take place due to the similar intermolecular forces present
- with agitation, this allows the detergent molecule to remove the fats/oil/grease/dirt from the object
- soaps form an insoluble ppt (scum) with the Ca^{2+} or Mg^{2+} ions present in hard water but detergents do not

End of Section Two

SEE NEXT PAGE

Section Three: Extended answer**40% (80 marks)**

This section contains **five (5)** questions. You must answer **all** questions. Write your answers in the spaces provided below.

Where questions require an explanation and/or description, marks are awarded for the relevant chemical content and also for coherence and clarity of expression. Lists or dot points are unlikely to gain full marks.

Final answers to calculations should be expressed to the appropriate number of significant figures.

Spare pages are included at the end of this booklet. They can be used for planning your responses and/or as additional space if required to continue an answer.

- Planning: If you use the spare pages for planning, indicate this clearly at the top of the page.
- Continuing an answer: If you need to use the space to continue an answer, indicate in the original answer space where the answer is continued, i.e. give the page number. Fill in the number of the question(s) that you are continuing to answer at the top of the page.

Suggested working time: 70 minutes.

Question 36**(17 marks)**

Hydrogen sulfide (H_2S) is a poisonous, colourless gas with the distinctive odour of rotten eggs. It is found in some types of rock salt, as well as volcanic gas and natural gas. Some sources of spring water with high hydrogen sulfide levels are used as medicinal baths, and there is evidence to suggest that H_2S may have some anti-ageing properties.

When hydrogen sulfide gas dissolves in water, it ionises as shown in the equations below to produce the following equilibria, which is comprised of the three sulfur-containing species (H_2S , HS^- and S^{2-}).

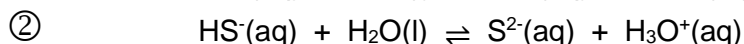
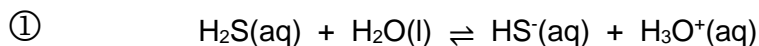

Scientists noted that the percent of each sulfur-containing species (H_2S / HS^- / S^{2-}) present in a given aqueous sample was dependent upon the pH of the solution. An investigation was conducted to examine how the concentrations of each of these sulfur-containing species changed with respect to pH. The results of the investigation are displayed in the graph below.

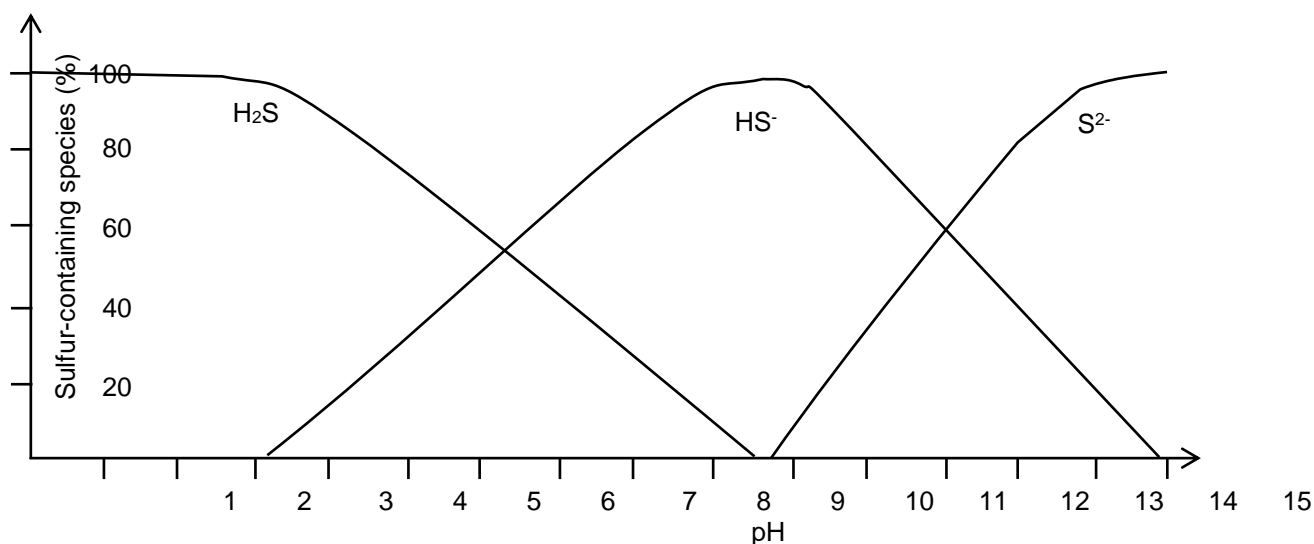
**SEE NEXT PAGE**

- (a) State each of the variables for the investigation described above. (3 marks)

Independent	pH
Dependent	% abundance of sulfur-containing species
Controlled	temperature of water / surroundings, atmospheric pressure

- (b) Using your knowledge of collision theory and chemical equilibrium, explain the results displayed in this graph. (4 marks)

- **a decrease in pH corresponds to an increase in H_3O^+ concentration**
- **this will result in more collisions between $\text{H}_3\text{O}^+/\text{S}^{2-}$ and $\text{H}_3\text{O}^+/\text{HS}^-$**
- **this will favour the reverse reactions in both equations 1 and 2 and result in a higher amount of H_2S being present**
- **an increase in pH will have the opposite effect, with forward reactions being favoured to produce more HS^- and then subsequently more S^{2-}**

Hydrogen sulfide is often found in sources of drinking water, as it is produced by the decomposition of organic matter. It can cause the water to have an unpleasant smell and taste when present in as little as 0.05 mg L^{-1} concentrations. Hydrogen sulfide can be removed from water sources by the addition of chlorine gas, which reacts according to the equation below.

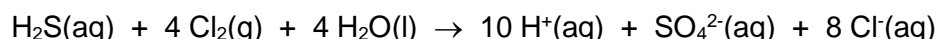

- (c) Use oxidation numbers to demonstrate that this is a redox reaction. State which substance is oxidised and reduced in this process. (2 marks)

- **S in H_2S oxidised, ON changes from (-2) to (+6)**
- **Cl_2 reduced, ON changes from (0) to (-1)**

A 2000 L tank of water contaminated with hydrogen sulfide at a concentration of 0.173 mg L^{-1} was to be treated with chlorine gas. If the chlorine was stored under a pressure of 395 kPa and at a temperature of $20.0 \text{ }^\circ\text{C}$;

- (d) Calculate the volume of chlorine gas that would be required to remove all the hydrogen sulfide from the water. (You may disregard the presence of other sulfur-containing species and assume all the chlorine gas added will dissolve in the water). (5 marks)

$$\begin{aligned} m(\text{H}_2\text{S in 2000 L water}) &= cV \\ &= 0.173 \times 2000 \\ &= 346 \text{ mg} \\ &= 0.346 \text{ g} \end{aligned}$$

$$\begin{aligned} n(\text{H}_2\text{S}) &= m / M \\ &= 0.346 / 34.086 \\ &= 0.0101508 \text{ mol} \end{aligned}$$

$$\begin{aligned} n(\text{Cl}_2) &= 4 \times n(\text{H}_2\text{S}) \\ &= 0.040603 \text{ mol} \end{aligned}$$

$$\begin{aligned} V(\text{Cl}_2) &= nRT / P \\ &= (0.040603 \times 8.314 \times 293.15) / 395 \\ &= 0.2505 \text{ L} \\ &= 0.251 \text{ L OR } 251 \text{ mL (3SF)} \end{aligned}$$

- (e) Calculate the final pH of the water in the tank after the chlorination process was complete and all the hydrogen sulfide had been removed. (You may disregard the presence of other sulfur-containing species and assume that the original pH of the water was 7). (3 marks)

$$\begin{aligned} n(\text{H}^+) &= 10 \times n(\text{H}_2\text{S}) \\ &= 0.101508 \text{ mol} \end{aligned}$$

$$\begin{aligned} C(\text{H}^+) &= n / V \\ &= 0.1015008 / 2000 \\ &= 5.0754 \times 10^{-5} \text{ mol L}^{-1} \end{aligned}$$

$$\begin{aligned} \text{pH} &= -\log [\text{H}^+] \\ &= -\log (5.0754 \times 10^{-5}) \\ &= 4.29 \text{ (3SF)} \end{aligned}$$

Question 37**(15 marks)**

Ammonia (NH₃) is produced industrially by the Haber process. Ammonia is an important chemical, particularly in the agricultural industry, where it is used to produce many different types of fertilisers. The Haber process involves the reaction between gaseous nitrogen and hydrogen to produce ammonia. The nitrogen gas is extracted from air, whilst the hydrogen gas is produced via the 'shift' and 'steam reforming' processes, using methane from natural gas.

The two equations below can be used to summarise the chemical processes involved in industrial ammonia production. Step 1 represents the overall process that produces hydrogen gas from methane, and Step 2 shows the subsequent reaction with nitrogen gas to produce ammonia.

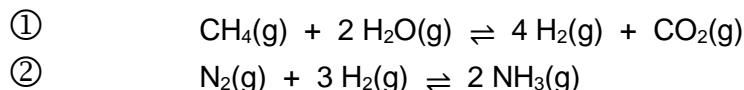

The conditions for Step 2 are optimised for both rate and yield of ammonia production. A pressure of between 100-350 atm is maintained and a moderate temperature of 350-550 °C is used, in conjunction with an Fe₃O₄ catalyst. Using these conditions, a yield of 20-30% is obtained for each reaction cycle, but the overall yield is much closer to 100% due to the continuous cycling of unreacted materials back through the chamber.

If 311 tonnes of nitrogen gas and 71.0 tonnes of hydrogen gas are injected into a reaction chamber with a 25 000 kL capacity;

- (a) Calculate the initial pressure inside the reaction chamber if the temperature was maintained at 450 °C. (4 marks)

$$\begin{aligned} n(\text{N}_2) &= m / M \\ &= 311 \times 10^6 / 28.02 \\ &= 1.1099 \times 10^7 \text{ mol} \end{aligned}$$

$$\begin{aligned} n(\text{H}_2) &= m / M \\ &= 71.0 \times 10^6 / 2.016 \\ &= 3.5218 \times 10^7 \text{ mol} \end{aligned}$$

$$n(\text{gas total}) = 4.6317 \times 10^7 \text{ mol}$$

$$\begin{aligned} P(\text{total}) &= nRT / V \\ &= (4.6317 \times 10^7 \times 8.314 \times 723.15) / (25\,000 \times 10^3) \\ &= 11\,139 \text{ kPa} \\ &= 1.11 \times 10^4 \text{ kPa} \quad (3\text{SF}) \end{aligned}$$

- (b) Determine the limiting reagent. (2 marks)

$$\text{stoich ratio } \text{H}_2:\text{N}_2 = 3 / 1 = 3$$

$$\text{actual ratio } \text{H}_2:\text{N}_2 = 3.5218 \times 10^7 / 1.1099 \times 10^7 = 3.173$$

therefore H_2 in excess, N_2 is LR

After one reaction cycle, the yield of ammonia was determined to be 25.7%. This ammonia was removed from the chamber, liquefied and pumped into cylinders that each hold 400 kg of ammonia. These cylinders are used to store or transport the ammonia.

- (c) How many cylinders would you need to store the ammonia produced from one reaction cycle? (4 marks)

$$\begin{aligned} n(\text{NH}_3 \text{ produced}) &= 2 \times n(\text{N}_2) \times \% \text{ yield} \\ &= 2 \times 1.1099 \times 10^7 \times 0.257 \\ &= 5.705 \times 10^6 \text{ mol} \end{aligned} \quad (2\text{m})$$

$$\begin{aligned} m(\text{NH}_3) &= nM \\ &= 5.705 \times 10^6 \times 17.034 \\ &= 9.7179 \times 10^7 \text{ g} \\ &= 97179 \text{ kg} \end{aligned} \quad (1\text{m})$$

$$\begin{aligned} \text{cylinders required} &= 97179 / 400 \\ &= 242.9 \quad \text{ie 243 cylinders needed} \end{aligned} \quad (1\text{m})$$

If 150 tonnes of methane gas was used to produce the 71.0 tonnes of hydrogen used in this reaction;

- (d) Calculate the yield of Step 1. (3 marks)

$$\begin{aligned} n(\text{CH}_4) &= m / M \\ &= 150 \times 10^6 / 16.042 \\ &= 9.3505 \times 10^6 \text{ mol} \end{aligned}$$

$$\begin{aligned} n(\text{H}_2 \text{ theoretical}) &= 4 \times n(\text{CH}_4) \\ &= 3.7402 \times 10^7 \text{ mol} \end{aligned}$$

$$\begin{aligned} \% \text{ yield} &= n(\text{actual}) / n(\text{theoretical}) \times 100 \\ &= 3.5218 \times 10^7 / 3.7402 \times 10^7 \times 100 \\ &= 94.1619 \\ &= 94.2 \% \quad (3\text{SF}) \end{aligned}$$

- (e) Give two (2) reasons that may have contributed to the yield of Step 1 being lower than 100%. (2 marks)

- methane may not have been 100% pure
- reactions are reversible so unlikely to be complete conversion of reactants (other reasonable explanations e.g. loss of gases due to high pressure...)

Question 38**(20 marks)**

Biodiesel is commonly manufactured by a transesterification reaction between oil and methanol. There are many different types of oils that can be used in this process, providing great scope for the range of sources from which biodiesel can be manufactured.

- (a) Explain why biodiesel is considered a more sustainable 'green' alternative to traditional fuels such as petrol. (2 marks)

- **biodiesel is produced from renewable biomass which is more sustainable**
- **compared to non-renewable crude oil for petrol**

An example of the biodiesel-producing transesterification reaction is shown below using the oil *triolein*, which is one of the triglycerides commonly found in olive oil.

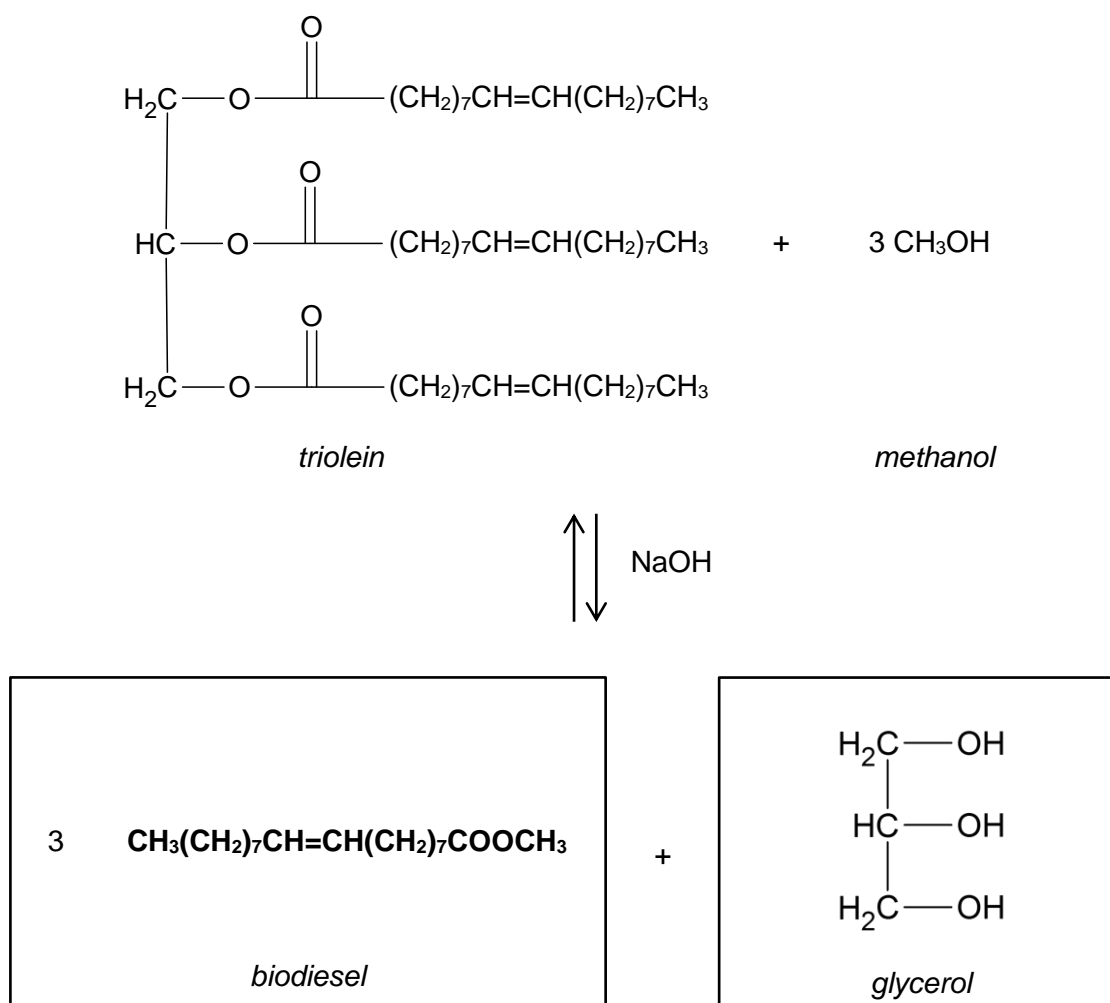

- (b) Complete the reaction above by filling in the boxes. (2 marks)

Due to the slow rate of the transesterification reaction, a sodium hydroxide (NaOH) catalyst is used and a temperature of around 60 °C is maintained.

(c) Explain how each of these factors increases the rate of reaction. (4 marks)

NaOH catalyst	<ul style="list-style-type: none"> - provides an alternative reaction pathway with a lower E_a - thereby allowing greater proportion of particles to overcome E_a barrier
Temperature of 60 °C	<ul style="list-style-type: none"> - increased average E_k means molecules are moving faster and colliding with greater force - results in increased number of collisions and a greater proportion of particles now having sufficient energy to overcome E_a barrier

During the manufacture of biodiesel, an unwanted side-reaction occurs where soap is produced. This is problematic as it reduces the purity of the biodiesel product and requires further refining to be performed before the biodiesel can be used or sold.

(d) Explain how this soap-producing reaction can occur. (Chemical equations are **not** required in your answer). (2 marks)

- **the NaOH catalyst can react directly with the oil**
- **this results in a saponification reaction where the oil forms soap instead of biodiesel**

To ensure that the levels of soap in commercial biodiesel are not too high, a 'soap test titration' is performed once a batch of biodiesel is produced. An acceptable level of purity requires the soap content of the biodiesel to be no higher than 41 ppm (parts per million).

To perform this titration, a sample of biodiesel is dissolved in pure isopropyl alcohol. Bromophenol blue indicator is added and a blue colour should be observed. The biodiesel is then titrated against a standard solution of hydrochloric acid (HCl) until a colour change from blue to yellow is observed.

The titration equation is given below.

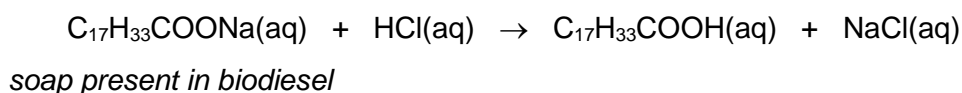

A 60.00 mL sample of a particular batch of biodiesel was taken and made up to 150.0 mL with pure isopropyl alcohol. 35.00 mL aliquots were then titrated against a standard $1.65 \times 10^{-4} \text{ mol L}^{-1}$ hydrochloric acid solution, requiring an average of 8.83 mL for equivalence. If the density of the biodiesel is 0.833 g mL^{-1} ;

- (e) Determine the soap content of this biodiesel sample in parts per million (ppm) and state whether or not the soap content is at an acceptable level for sale. (6 marks)

$$\begin{aligned} n(\text{HCl}) &= cV \\ &= 1.65 \times 10^{-4} \times 0.00883 \\ &= 1.45695 \times 10^{-6} \text{ mol} \end{aligned}$$

$$\begin{aligned} n(\text{soap in 35 mL aliquot}) &= n(\text{HCl}) \\ &= 1.45695 \times 10^{-6} \text{ mol} \end{aligned}$$

$$\begin{aligned} n(\text{soap in 150 mL}) &= 1.45695 \times 10^{-6} / 35 \times 150 \\ &= 6.24407 \times 10^{-6} \text{ mol} \\ &= n(\text{soap in 60 mL biodiesel}) \end{aligned}$$

$$\begin{aligned} m(\text{soap}) &= nM \\ &= 6.24407 \times 10^{-6} \times 304.434 \\ &= 0.0019009 \text{ g} \\ &= 1.9009 \text{ mg} \end{aligned}$$

$$\begin{aligned} m(\text{biodiesel}) &= \rho V \\ &= 0.833 \times 60 \\ &= 49.98 \text{ g} \\ &= 0.04998 \text{ kg} \end{aligned}$$

$$\begin{aligned} \text{ppm} &= \text{mg soap} / \text{kg biodiesel} \\ &= 1.9009 / 0.04998 \\ &= 38.0 \text{ ppm (3SF)} \end{aligned}$$

soap level is just below 41 ppm - yes, acceptable level for sale

Current research is focussing on alternate catalysts for biodiesel manufacture, and one of the most promising candidates is the enzyme *lipase*. When *lipase* is used to catalyse the transesterification reaction, this prevents the alternate soap-producing pathway from occurring.

- (f) Describe what an enzyme is and explain why enzymes are able to minimise the occurrence of unwanted side reactions. (4 marks)

- **enzymes are proteins which act as biological catalysts**
- **they speed up the rate of a reaction by providing an alternative reaction pathway with a lower E_a**
- **enzymes function due to their very specific protein shape, through a 'lock and key' mechanism**
- **this means they often only catalyse a single reaction type, therefore eliminating the possibility of unwanted side reactions**

Question 39**(15 marks)**

'Nylon 4/6' is a polymer which can be obtained as a fibre, film, rod or sheet. It has wide ranging applications owing to its high heat and chemical resistance in comparison with other nylons. It is most often used for electrical and electronic components, in particular those that must withstand high temperatures for a long period of time.

A segment of nylon 4/6 is shown in the diagram below.

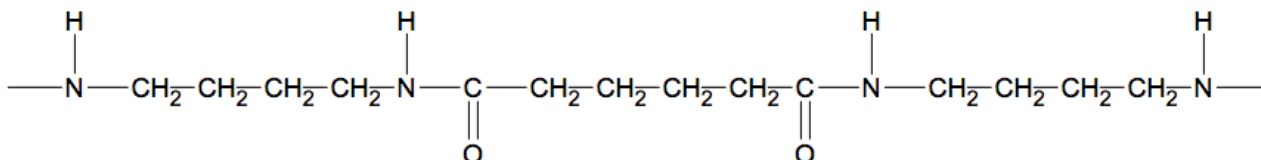

- (a) Nylons have the ability to form hydrogen bonds between polymer strands. How does this bonding affect the physical properties of nylon polymers? (2 marks)

any 2 of...

- **very strong / high tensile strength / resist wear and tear / can be made into weather proof substances / or those that must resist breaking or shearing etc**

- (b) Draw the two (2) monomers from which nylon 4/6 is composed. (2 marks)

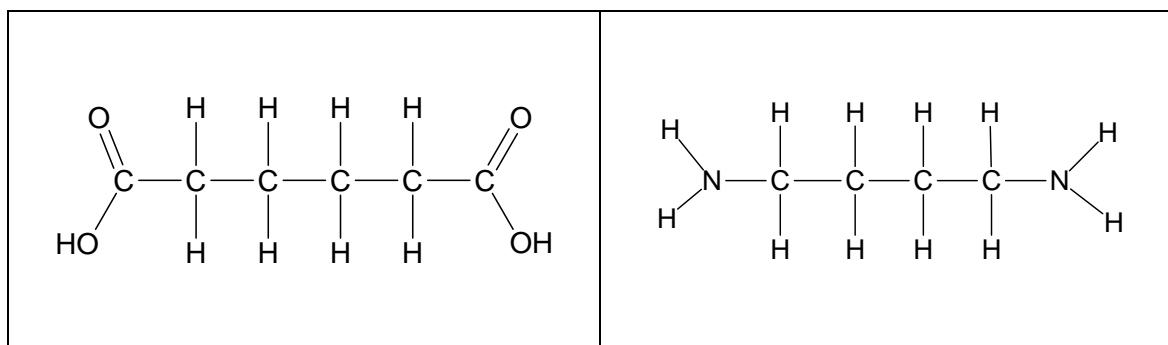

- (c) Name and briefly describe the process by which these monomers are able to form this nylon polymer. (2 marks)

- **condensation polymerisation**
- **a water molecule is eliminated (OH from each carboxylic acid group and H from each amine group) as the monomers link together to form nylon**

A pure sample of an amine (containing only the elements carbon, hydrogen and nitrogen) was analysed to determine its composition. The amine was combusted in oxygen and produced 6.43 g of carbon dioxide, 3.93 g of water and 2.04 g of nitrogen gas.

- (d) Calculate the empirical formula of the amine. (7 marks)

	C	H	N
m	$= 12.01 / 44.01 \times 6.43$ $= 1.754699 \text{ g}$	$= 2.016 / 18.016 \times 3.93$ $= 0.439769 \text{ g}$	$= 2.04 \text{ g}$
n	$= 1.754699 / 12.01$ $= 0.146103 \text{ mol}$	$= 0.439769 / 1.008$ $= 0.4362789 \text{ mol}$	$= 2.04 / 14.01$ $= 0.1456103 \text{ mol}$
ratio	1	3	1

Therefore EF is CH_3N

- (e) Did this analysis provide sufficient information to identify whether this amine is one of the monomers used to produce nylon 4/6? Explain. (2 marks)
- **yes the information proves this amine is not one of the monomers in the nylon 4/6 polymer**
 - **the MF of the polymer amine is $\text{C}_4\text{H}_{12}\text{N}_2$ which requires the EF to be $\text{C}_2\text{H}_6\text{N}$**

Question 40**(13 marks)**

A group of chemistry students set up an experiment to replicate the electrolytic refining of copper metal. They obtained some impure 'blister copper' as well as a thin piece of pure copper and set up an electrochemical cell as shown in the diagram below.

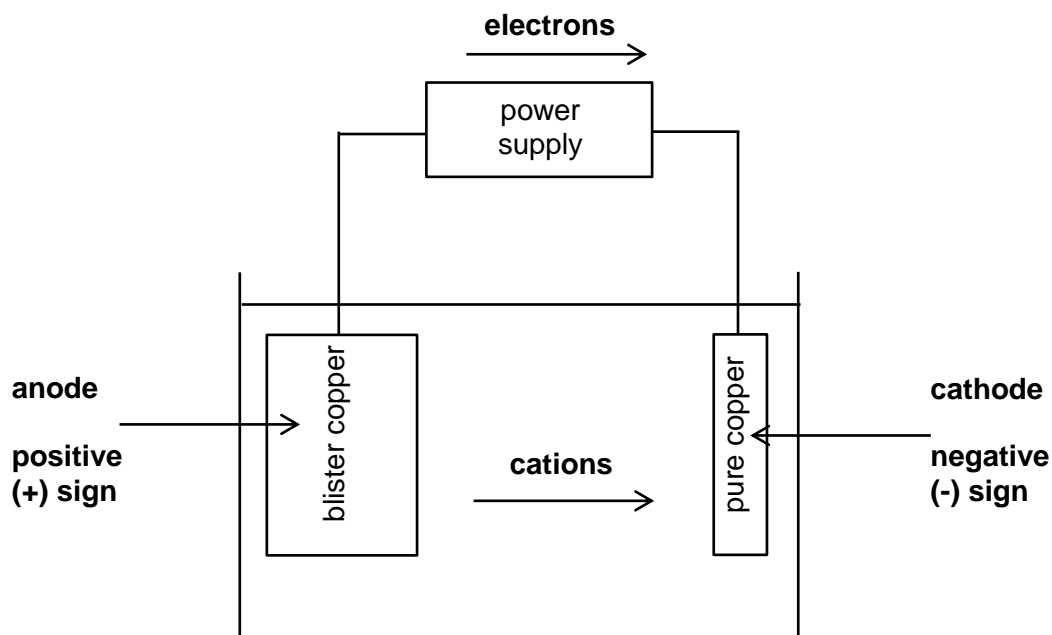

(a) Explain the chemical principles of an electrolytic cell. (2 marks)

- **electrolytic cells utilise an external applied voltage**
- **this drives a non-spontaneous redox reaction to occur**

(b) On the diagram above label; (4 marks)

- the anode and cathode
- the sign of each electrode
- the direction of cation flow
- the direction of electron flow

(c) State two (2) safety considerations the students would have to take into account when conducting this experiment. (2 marks)

- **any 2 acceptable precautions such as...**
- **wear safety glasses / take precautions when using electrical devices / avoid contact with copper sulfate electrolyte / keep voltage low to prevent electrolysis of water and production of flammable hydrogen etc**

The students recorded the mass of the blister copper and pure copper electrodes before allowing the cell to run for a period of time. They then recorded the mass of each electrode again. Their results are shown in the table below.

	Blister copper	Pure copper
Initial mass (g)	65.8	11.9
Final mass (g)	52.3	25.1

- (d) Calculate the percent purity of the blister copper. (3 marks)

$$\begin{aligned} \text{decrease in mass of blister copper} &= 65.8 - 52.3 \\ &= 13.5 \text{ g} \end{aligned}$$

$$\begin{aligned} \text{increase in mass of pure copper} &= 25.1 - 11.9 \\ &= 13.2 \text{ g} \end{aligned}$$

$$\begin{aligned} \% \text{ purity} &= 13.2 / 13.5 \times 100 \\ &= 97.8 \% \text{ (3SF)} \end{aligned}$$

- (e) What factors or problems with an experiment can cause; (2 marks)

(i) random error?

- **Uncontrollable (unpredictable or unknown) effects of equipment, procedure or environment (minimised by multiple trials and averaging)**

(ii) systematic error?

- **identifiable and quantifiable uncertainty, i.e. consistent bias or faults in measuring instruments or consistent errors in experimental techniques or procedure (minimised by using correct scientific technique)**

End of questions